

50B2.75S -62

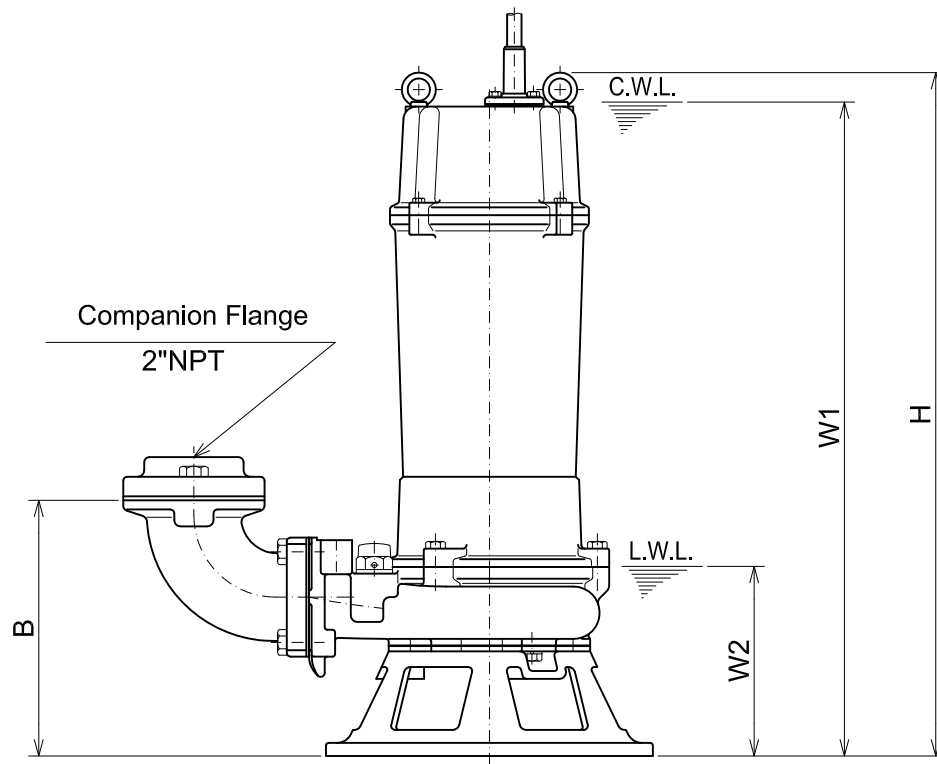
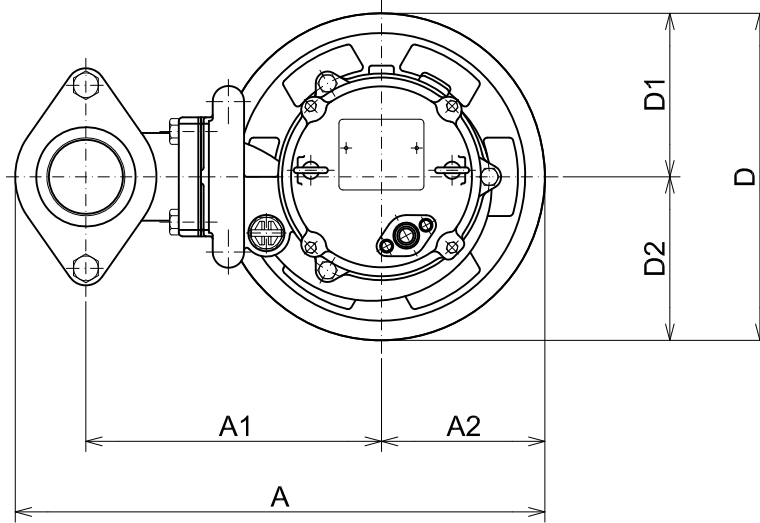

Companion Flange
2"NPT

C.W.L. :Continuous running Water Level
L.W.L. :Lowest running Water Level

DIMENSIONS:USCS(Inch)

Model	HP	NOM. SIZE	Pump & Motor							C.W.L.	L.W.L.	Wt. (lbs.)	
			A	A1	A2	B	D	D1	D2				H
50B2.75S -62	1	2"	15 15/16	8 7/8	4 15/16	7 11/16	9 13/16	4 15/16	4 15/16	20 9/16	19 5/8	5 3/4	71

DIMENSIONS:METRIC(mm)

Model	kW	NOM. SIZE	Pump & Motor							C.W.L.	L.W.L.	Wt. (kg)	
			A	A1	A2	B	D	D1	D2				H
50B2.75S -62	0.75	50	405	226	125	196	250	125	125	523	500	145	32

TOS50B2.75S -62

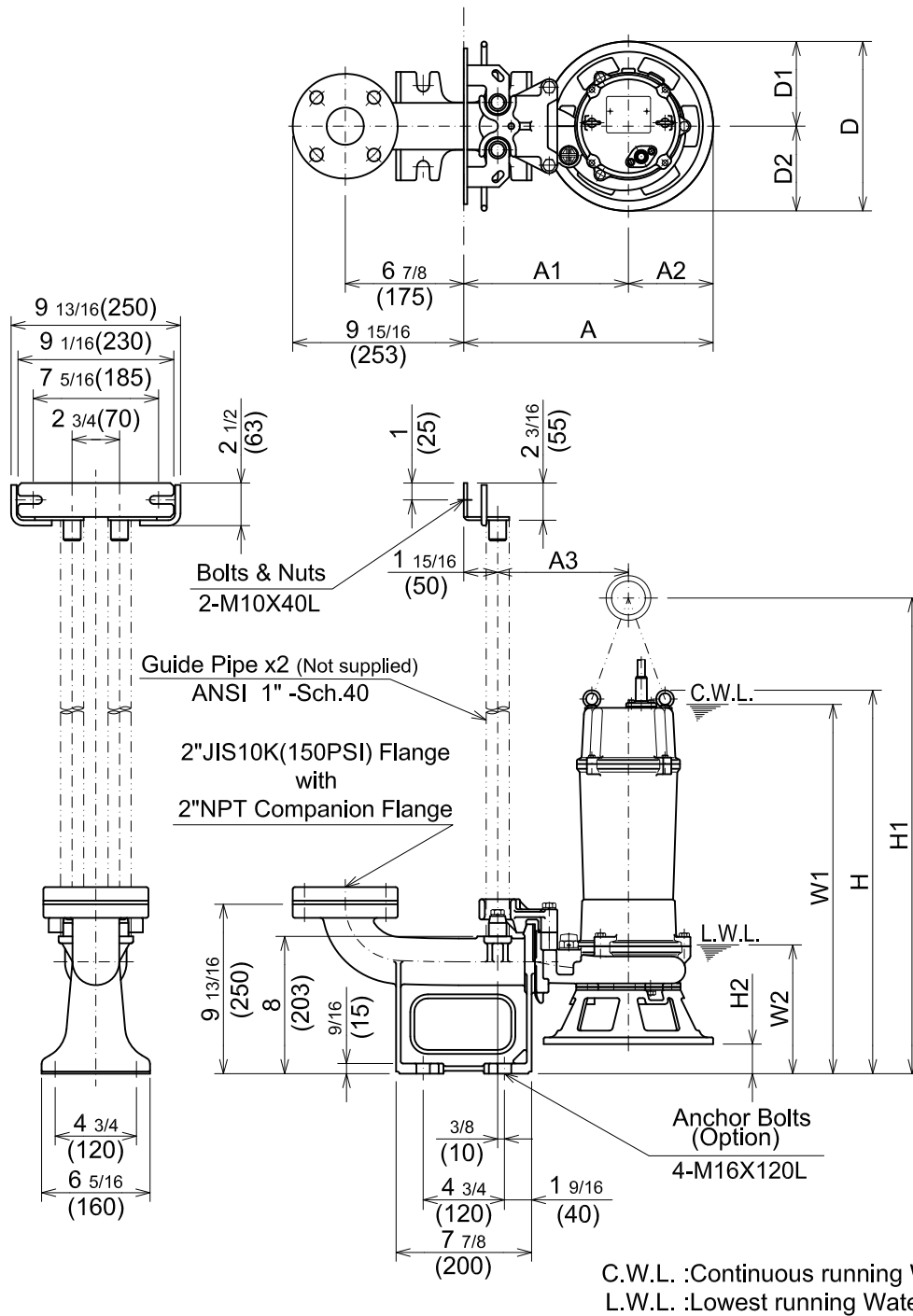

C.W.L. :Continuous running Water Level
L.W.L. :Lowest running Water Level

DIMENSIONS:USCS(Inch)

Model	HP	NOM. SIZE	Pump & Motor										C.W.L.	L.W.L.	Wt. (lbs.)
			A	A1	A2	A3	D	D1	D2	H	H1	H2			
TOS50B2.75S -62	1	2"	14 1/2	9 9/16	4 15/16	7 5/8	9 13/16	4 15/16	4 15/16	22 5/16	27 5/8	1 3/4	21 1/2	7 1/2	66

DIMENSIONS:METRIC(mm)

Model	kW	NOM. SIZE	Pump & Motor										C.W.L.	L.W.L.	Wt. (kg)
			A	A1	A2	A3	D	D1	D2	H	H1	H2			
TOS50B2.75S -62	0.75	50	368	243	125	193	250	125	125	566	702	44	545	190	30



B-SERIES
SEWAGE & WASTEWATER PUMPS

PERFORMANCE
CURVE

MODEL	BORE	HP	KW	RPM	SOLIDS DIA.	LIQUID	SG.	VISCOSITY	TEMP.
(TOS)50B2.75S -62	2"/50mm	1	0.75	3455	0.79"/20mm	Water	1.0	1.123cSt.	60°F
PUMP TYPE	PHASE	VOLTAGE	AMPERAGE	HZ	STARTING METHOD	INS.CLASS			
Sewage&Wastewater	1	115/120/230	11.7/11.5/5.9	60	Capacitor-Start	E			
CURVE No.	DATE	PHASE	VOLTAGE	AMPERAGE	HZ	STARTING METHOD	INS.CLASS		
-	-	-	-	-	-	-	-		

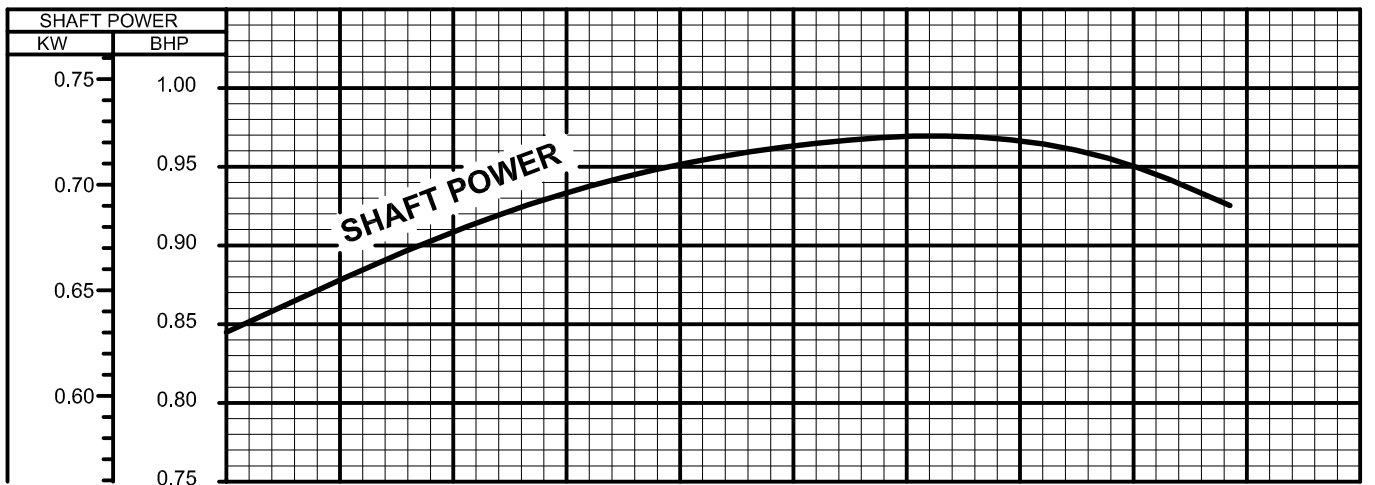
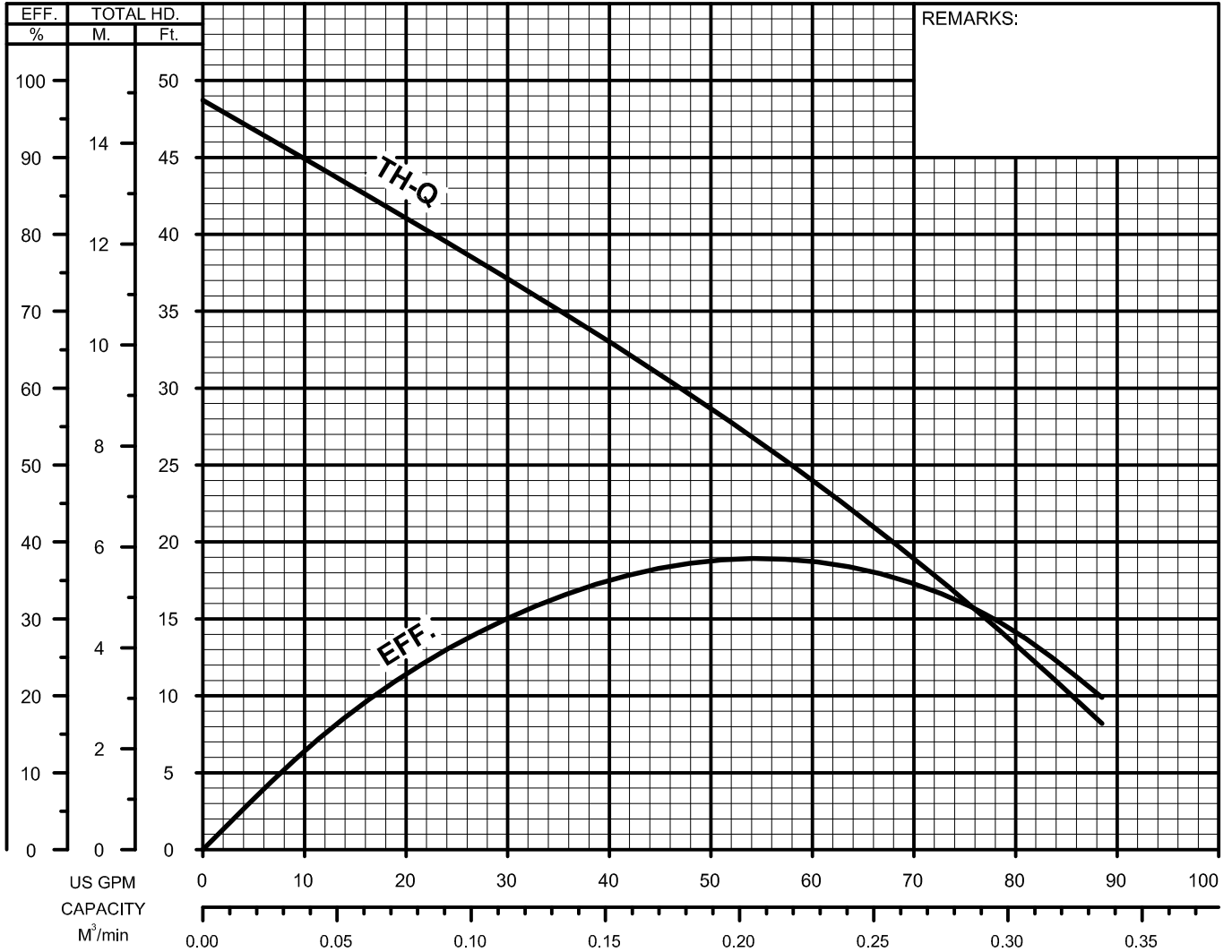

50B2.75S -62

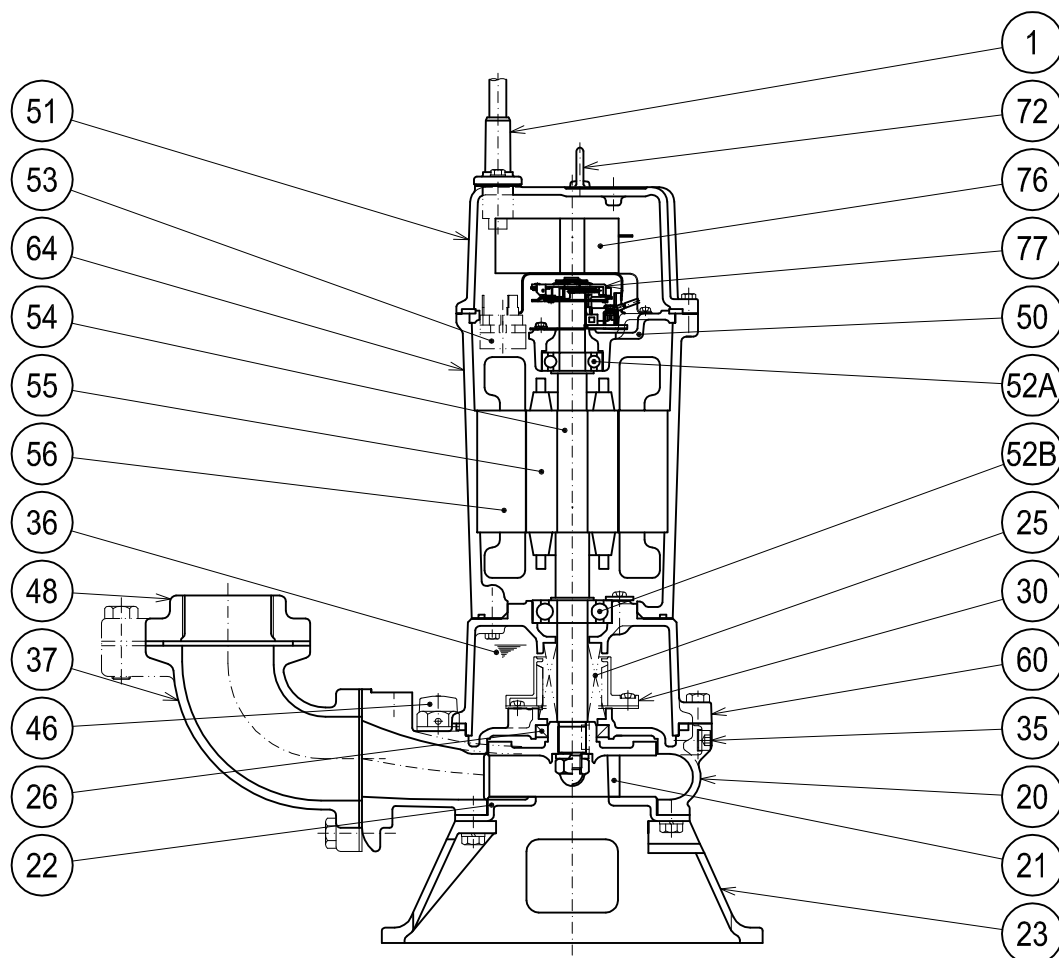

PART#	DESCRIPTION	MAIN MATERIAL / NOTE	RELATED ASTM,AISI CODE	RELATED EN CODE	QTY
1	Power Cable	PVC Sheath AWG 14/3-32ft (115/120V) or AWG 16/3-32ft (230V)			1
20	Pump Casing	Cast Iron	A48M Class30B	EN 1561 GJL-200	1
21	Impeller	Cast Iron	A48M Class30B	EN 1561 GJL-200	1
22	Suction Cover	Cast Iron	A48M Class30B	EN 1561 GJL-200	1
23	Suction Strainer	Cast Iron	A48M Class30B	EN 1561 GJL-200	1
25	Mechanical Seal	Silicon Carbide / H-20			1
26	Oil Seal	NBR / TC32488			1
30	Oil Lifter	PBT Resin W/GF40			1
35	Oil Plug	Stainless Steel	S 30400	1.4301	1
36	Lubricant	Turbine Oil ISO VG32 or SAE 10W-20			
37	Discharge Bend	Cast Iron	A48M Class30B	EN 1561 GJL-200	1
46	Air Release Valve	Nylon			1
48	Companion Flange	Cast Iron / NPT 2"	A48M Class30B	EN 1561 GJL-200	1
50	Motor Bracket	Cast Iron	A48M Class25B	EN 1561 GJL-150	1
51	Head Cover	Cast Iron	A48M Class25B	EN 1561 GJL-150	1
52A	Upper Bearing	#6203ZZC3			1
52B	Lower Bearing	#6304ZZC3			1
53	Motor Protector				1
54	Shaft	Stainless Steel	S 42000	1.4028	1
55	Rotor				1
56	Stator				1
60	Bearing Housing	Cast Iron	A48M Class25B	EN 1561 GJL-150	1
64	Motor Housing	Cast Iron	A48M Class25B	EN 1561 GJL-150	1
72	Lifting Lug Bolt	Stainless Steel	S 30400	1.4301	2
76	Capacitor				1
77	Centrifugal Switch				1

PARTS LIST		SEWAGE & WASTEWATER PUMPS			7/13/2016	
ITEM	PART No.	DESCRIPTION	QTY	SIZE	MATERIAL	NOTES
1	003-190-10	Gland	1		SUS316	
2	001-471-12	Cabtyre Cable Set (32')110V-60Hz	1	VCT3Cx2.0mm2		110V plug
	001-443-31	Cabtyre Cable Set (32') 220V-60Hz)	1	VCT3Cx2.0mm2		220V no plug
3	140-427-17	Hex.Bolt (w/Plain Washer)	2	M5x15	SUS304	
4	072-120-26	Eye Bolt	2	M6	SUS304	
5	140-022-18	Hex.Bolt	4	M5x25	SUS304	
6	121-252-10	Packing	1	d127.3xd144.8x3.5t	NBR	*
7	051-156-13	Motor Head Cover	1		FC	
8	009-001-06	Earth Terminal	1Set	1.25mm2x80L		
9	143-085-21	Pan Screw (w/Spring Washer)	1	M4x6	SWRM	
10	143-085-21	Pan Screw (w/Spring Washer)	2	M4x6	SWRM	
11	127-000-33	Capacitor Fixing Plate	1		SPC	
12	076-000-11	Capacitor	1	240MF-125VAC(L=80)	(T)	
13	121-268-19	Rubber Sheet	1	35x50x3t	Rubber	
14	078-000-01	Centrifugal Switch Cover	1		SPC	
15	143-086-22	Pan Screw (w/Spring Washer)	2	M4x8	SWRM	
16	145-002-17	Snap Retainer	1	d10	SK5	
17	077-110-15	Centrifugal Switch	1Set	MS-5-2T		
18	143-086-22	Pan Screw (w/Spring Washer)	2	M4x8	SWRM	
19	142-207-15	Finger Spring	1	d10.5	SK5	
20	143-076-29	Pan Screw (w/Spring Washer)	2	M3x6	SWRM	
21	143-126-38	Pan Screw (w/Spring Washer/Plain Washer)	2	M4x12	SWRM	
22	053-282-15	Motor Protector 110V-60Hz	1	KA112-ABVL17	(H)	
	053-263-10	Motor Protector 220V-60Hz	1	KA112-BATL09	(H)	
23	016-100-13	Lead Wire Protection Bush	2	S-400(E)	NBR	
24	050-273-14	Motor Bracket	1		FC	
25	142-194-18	Wave Washer	1	6203	SK5	
26	052-102-17	Bearing	1	6203ZZC3		
27	061-152-10	Bearing Collar	1	d17.1xd23x1.6t	SPC	
28	055-002-25	Rotor	1Set	w/Bearing		
29	147-115-10	Impeller Key	1	5x5x15.5L	SUS403	
30	061-158-16	Bearing Collar	1	d20.1xd28x1.6t	SPC	
31	056-007-01	Stator 110V-60Hz	1Set			
	056-007-03	Stator 220V-60Hz	1Set			
32	064-320-10	Motor Frame	1		FC	
33	122-134-18	O-Ring	1	G-115(114.4xd3.1)	NBR	*
34	122-128-19	O-Ring	1	G-85(84.4xd3.1)	NBR	*
35	052-107-12	Bearing	1	6304ZZC3		

PARTS LIST		SEWAGE & WASTEWATER PUMPS			7/13/2016	
ITEM	PART No.	DESCRIPTION	QTY	SIZE	MATERIAL	NOTES
36	140-000-23	Hex.Bolt (w/Spring Washer)	2	M5x10	SWRM	
37	062-187-17	Bearing Fixing Washer	2	d5.5xd18x2.3t	SPC	
38	060-261-10	Bearing Housing	1		FC	
39	140-056-11	Hex.Bolt	3	M8x30	SUS304	
40	140-021-17	Hex.Bolt	4	M5x20	SUS304	
41	025-252-19	Mechanical Seal	1	H-20A	SiC+CCBN	
42	143-070-23	Pan Screw	2	M5x6	SWRM	
43	030-144-13	Oil Lifter	1	H-20(A)(T)	Resin	
44	030-153-15	Seal Stopper	1	H-20(A)	SPCC	
45	143-070-10	Pan Screw	2	M5x6	SWRM	
46	122-072-17	O-Ring	1	P-140(139.6xd5.7)	NBR	*
47	035-112-17	Oil Plug	1	M8x12	SUS304	
48	121-248-13	Packing	1	d8.2xd13.5x2t	PE	*
49	020-610-14	Pump Casing	1	8-BEH2	FC	
50	046-107-13	Air Release Valve	1	PT-1/2	Nylon	
51	026-107-11	Oil Seal	1	TC-32488	NBR	
52	040-104-25	Impeller Shim		d18.2xd29x0.3t	SUS304	
53	021-730-14	Impeller (50Hz) OPTION	1	50B2.75S-52	FC	50Hz OPTION
	021-731-15	Impeller (60Hz)	1	50B2.75S-62	FC	
54	142-165-10	Spring Washer	1	M12	SUS304	
55	141-118-15	Hex.Cap Nut	1	M12(H=15.5)	SUS304	
56	120-145-16	Packing (S.Cover)		d112xd129x0.3t	PE	
57	022-569-13	Suction Cover	1	8-BE2	FC	
58	140-475-10	Hex.Bolt (w/Spring Washer)	3	M8x16	SUS304	
59	023-001-25	Strainer Stand	1	No.1(8-BE2/CE2)	FC	
60	140-476-11	Hex.Bolt (w/Spring Washer)	3	M8x25	SUS304	
61	048-104-16	Screwed Flange	1	50mm(P.C.140)	FC	
	048-105-17	Screwed Flange OPTION	1	65mm(P.C.140)	FC	2.5" discharge OPTION
	048-182-18	Screwed Flange OPTION	1	80mm(P.C. 140)	FC	3" discharge OPTION
62	140-099-16	Hex.Bolt	2	M12x40	SUS304	
63	121-137-18	Packing	1	MBT(P.C.140)	NBR	*
64	037-117-18	Discharge Bend	1	50mm(122-16)	FC	
65	140-077-18	Hex.Bolt	4	M10x32(B=14)	SUS410	
66	121-142-16	Packing	1	90mm2(P.C.98)	NBR	*
	173-370-16	Packing O-Ring Set	1Set	(Marked by *)		
6	121-252-10	Packing (Head Cover/M.Frame)	1	d127.3xd144.8x3.5t	NBR	*
33	122-134-18	O-Ring (M.Frame/Brg.Housing)	1	G-115(114.4xd3.1)	NBR	*
34	122-128-19	O-Ring (M.Frame/Brg.Housing)	1	G-85(84.4xd3.1)	NBR	*



MODEL **50B2.75S-62**

PARTS LIST		SEWAGE & WASTEWATER PUMPS			7/13/2016	
ITEM	PART No.	DESCRIPTION	QTY	SIZE	MATERIAL	NOTES
46	122-072-17	O-Ring (Brq.Housing/P.Casing)	1	P-140(139.6xd5.7)	NBR	*
48	121-248-13	Packing (Oil Plug)	1	d8.2xd13.5x2t	PE	*
63	121-137-18	Packing (Screwed Flange)	1	MBT(P.C.140)	NBR	*
66	121-142-16	Packing (Discharge Bend)	1	90mm2(P.C.98)	NBR	*
		Lubricant		Turbine Oil VG32 590ml		

PARTS LIST		SEWAGE & WASTEWATER PUMPS				7/13/2016
ITEM	PART No.	DESCRIPTION	QTY	SIZE	MATERIAL	NOTES

EXPLODED VIEW

50B2.75S-52/62

